

Double Disc Check Valve

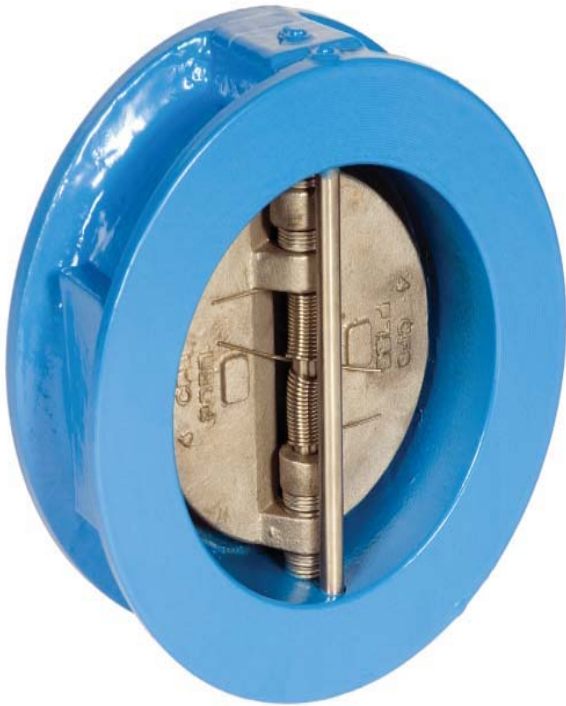

Operation and Maintenance Manual

Job Name: _____

Contractor: _____

Date: _____

SAFETY MESSAGES

All safety messages in the instructions are flagged with an exclamation symbol and the word “Warning”. These messages indicate procedures that must be followed exactly to avoid equipment damage, physical injury, or death. Safety labels on the product indicate hazards that can cause equipment damage, physical injury, or death.



WARNING

Personnel involved in the installation or maintenance of valves should be constantly alert to potential emission of pipeline material and take appropriate safety precautions. Always wear suitable protection when dealing with hazardous pipeline materials.

PARTS

Order parts from your local Henry Pratt sales representative or directly from Henry Pratt Company. When ordering parts, please include the serial number located on the valve tag.

WARRANTY ISSUE

Seller warrants that, at its option, it will repair, replace, or refund the unit purchase price of any products which are non-conforming due to Seller’s material or workmanship during the warranty period. The warranty period shall be twelve (12) months for parts and eighteen (18) months for all other goods after date of shipment. This shall be Buyer’s sole remedy. In order to maintain this product warranty, Buyer must give written notice to Seller’s Field Service Supervisor prior to any work being performed.

IN CONSIDERATION OF THE FOREGOING, SELLER EXCLUDES ALL OTHER EXPRESS OR IMPLIED WARRANTIES, INCLUDING BUT NOT LIMITED TO MERCHANTABILITY AND FITNESS FOR A PARTICULAR PURPOSE.

Seller does not warrant water operated metallic cylinders against damage caused by corrosion, electrolysis or mineral deposits. In no event shall warranty include valve removal or reinstallation.



WARNING

Read all applicable directions and instructions prior to any maintenance, troubleshooting or installation



Double Disc Check Valves

Table of Contents

INTRODUCTION	4
RECEIVING AND STORAGE	4
DESCRIPTION OF OPERATION	4
INSTALLATION	5
VALVE CONSTRUCTION	6
MAINTENANCE	7
CONTACTING PRATT	10

Double Disc Check Valves

INTRODUCTION

This manual will provide the owner of a double disc check valve the information to operate and maintain the valve to ensure a long and satisfactory operating life. The double disc check valve is built with stainless trim to give years of trouble free operation and to ensure compliance to NSF61 or Annex G standards. The double disc check valve can be installed in either horizontal or vertical pipelines that carry clean water or air. This valve is not intended to carry fluids containing solids such as raw sewage or wastewater. This valve is not suited for fluids that contain hazardous gases.

The double disc check valve is designed to provide flow in the direction of the arrow marked on the outside nameplate, and instantaneously close upon sensing flow reversal. The nameplate will also indicate valve size, model number, working pressure and materials of construction.

RECEIVING AND STORAGE

When valves arrive on site they should be inspected for any shipping damage. Valves should be off loaded from their carrier without being dumped or dropped. When lifting the valve use lifting straps around the body and never lift a valve with straps or chains through the body.

Valves should remain in their original shipping container until ready to install into the pipeline. This will prevent any weather related damage to occur and void the warranty. For extended periods of storage the container should remain closed so to not expose the valves seat materials to direct sunlight or ozone.

DESCRIPTION OF OPERATION

The double disc check valve is designed to prevent flow reversal in applications where this situation can occur. In pumping applications the pump will start the flow of water in the direction that is noted in figure 1.

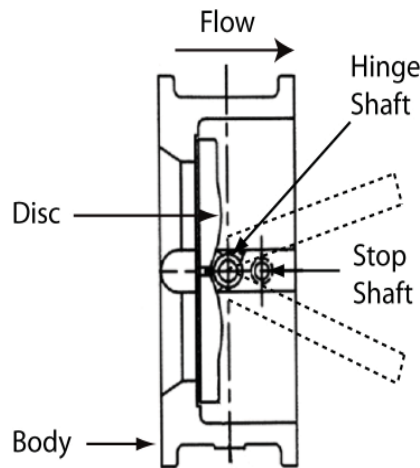

Figure 1
Double Disc Check Valve

DESCRIPTION OF OPERATION (Cont.)

The flow of water will push against the twin discs and force them back away from the body seat. The water will then flow through the valve between the two discs and body seat, as long as the water pressure keeps the valve open. When the pump stops and water ceases to flow the spring behind the discs will push the discs closed against the body and seal off the flow of water in the opposite direction of flow. The disc closure occurs before the flow of water can reverse thus silencing the operation of the check valve. Typical check valve operation will cause valve slam or water hammer which is due to some degree of flow reversal.

The only moving parts in the double disc check valve are the twin discs and spring. The discs and spring are guided in the body with a hinge pin and a full open disc stop pin. The pins are captured within the valve body and a dampening material is used to eliminate vibration. The resilient body seat provides a drop tight seal for any applicable flow media.

INSTALLATION

The double disc check valve is installed in the pipeline between two flanges. The flow arrow that is stamped on the nameplate must point in the direction of fluid flow when the pump is running or when the system is in operation. The valve can be installed either vertically or horizontally, with the flow up. For ease of future reference install the valve with the nameplate in the visible orientation.

The valve will be installed between two flanges in accordance with ANSI B16.1, Cl. 125, ANSI B16.5 Cl. 150 or AWWA C207, Cl. D or E. Flange faces must be flat faced and flanges with raised faces cannot be used. When mating the double disc check valve with isolation valves, the downstream isolation valve must be at least one pipe diameter away of the check valve to avoid hitting the discs. The double disc disc edge will extend past the flange face, so it may interfere with the operation of the adjacent valve.



WARNING

CAUTION: When installing the double disc check valve in horizontal piping systems be sure to install the valve in an orientation that puts the disc hinge in the vertical position.

CAUTION: Do not install valves between flanges with raised faces. Damage to check valve will occur.

Lower valve into position between mating flanges using slings or chains wrapped around valve body. Never support the valve from within the valve body or valve trim. On larger valves a tapped hole on the top of the valve allows for the use of a lifting eye.

Double Disc Check Valves

VALVE CONSTRUCTION

The standard double disc check valve body is made from ductile iron. The balance of the internal wetted components are made from type 304 stainless steel. The disc and spring are the only moving parts and require no lubrication or maintenance. Reference cross section figure 2.

The body is a compact wafer type that fits between two pipe flanges. The Buna-N seat is bonded to the body and if damaged is not field repairable.

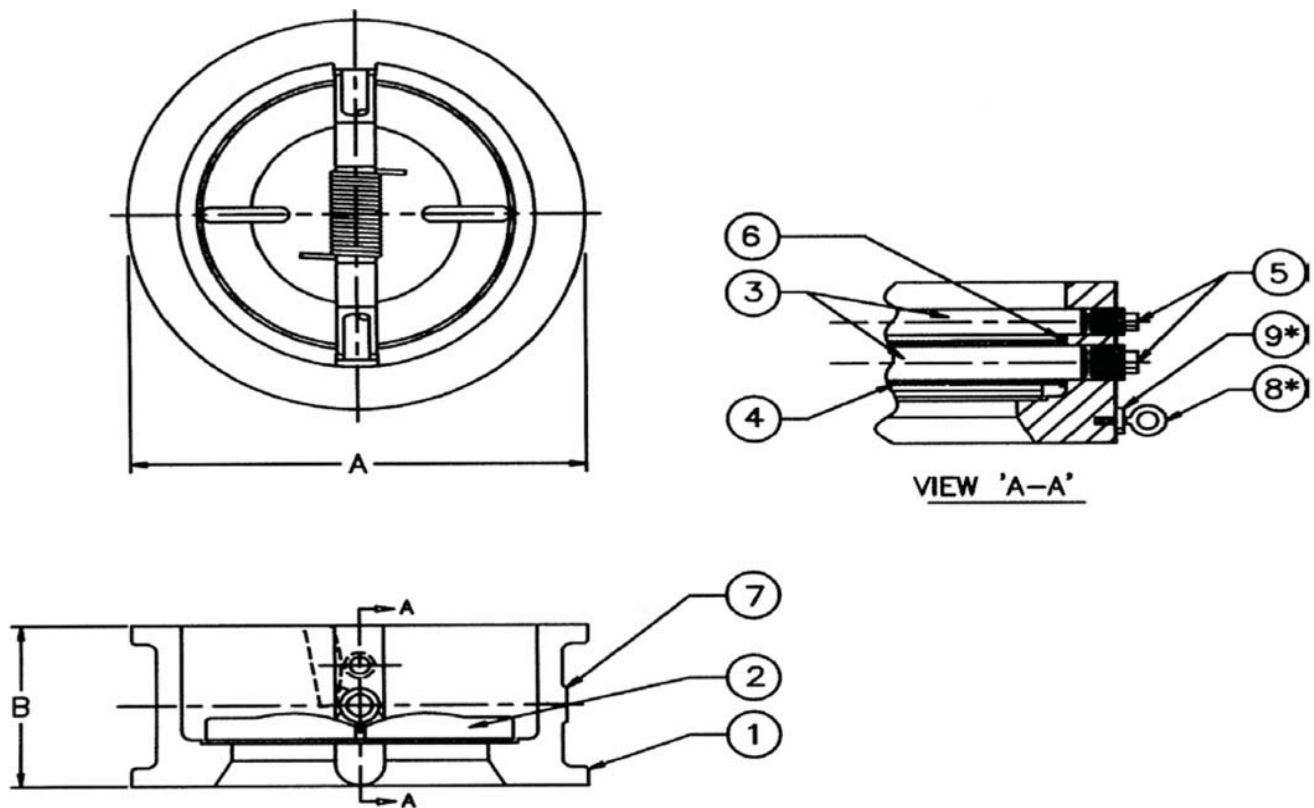

MATERIALS OF CONSTRUCTION

ITEM	QTY	DESCRIPTION	MATERIAL
1	1	BODY	DUCTILE IRON
2	2	DISC	STN. STL.
3	2	SHAFT	STN. STL.
4	2	SPRING	STN. STL.
5	4	PLUG	STEEL
6	AR	WASHER	STN. STL.
7	1	NAME PLATE	ALUMINUM
8*	2	EYE BOLT	STEEL
9*	2	HEX NUT	STEEL

*NOTE: ITEMS 8 & 9 FOR 8"-12" VALVES ONLY

MAINTENANCE

The double disc check valve is lubrication and maintenance free. Once the double disc check valve is installed correctly it will provide the end user many years of trouble free service.

TROUBLESHOOTING

A list of problems and associated solutions are presented to assist in troubleshooting the valve assembly.

Valve experiences noisy vibration or emits a chatter sound

- Flow velocity needs to be at least 4 feet per second or better. A partially open valve will wear prematurely. Verify that there are at least 3 pipe diameters of straight pipe upstream of valve

Valve Leakage

- In horizontal piping applications verify disc pin is in vertical position.
- Debris caught in valve. Remove valve and inspect seating surfaces.

Valve does not allow flow to occur

- Verify flow arrow is in proper orientation.
- Verify debris is not in line.

Valve Slams

- Remove valve and inspect spring. Spring may have broken.
- Disc bushing is getting clogged with debris – disc is getting stuck open.

Double Disc Check Valves

DISASSEMBLY



WARNING

CAUTION: All work performed on any check valve should be made when the valve is fully removed from the pipeline and executed by a trained mechanic using the correct tools.

1. Lay valve flat on bench with flow arrow facing up. Remove square head threaded hinge pin and stop pin retainers and rubber vibration material.
2. Remove pins by driving out from opposite end using a pin punch, while holding down the springs. Use a board and clamp to retain the spring.



WARNING

The valve spring can rapidly uncoil and cause bodily injury. Secure spring with boards and clamps during maintenance.

3. Lift discs from body. Inspect pins and seats for wear. The shaft diameter is about 1/32" smaller in diameter than the hole in the disc lugs. Some minor dents and discoloration are normal. Wear in the resilient seat will cause leakage and require valve replacement or refurbishment.
4. Inspect spring for wear or cracks.
5. Remove bearings and inspect for wear.

REASSEMBLY

NOTE: Prior to assembly all parts should be cleaned and body gasket faces should be wire brushed to remove any residual gasket material to ensure an effective sealing surface. Never use old or used gaskets during installation.

1. Lay body on flat surface with arrow facing upwards. Place the two discs with the machined seating surface down on the body seating surface. Align the disc lugs with the body pin holes.
2. Place washers on top of discs and partially install disc pin.
3. Install one end of spring, hooking spring arm behind the disc lug. Torque spring one half turn and hook other arm to the opposite disc lug. Insert shaft further to hold spring in place and install remaining washers on bottoms of discs. Complete insertion of disc shaft.



Double Disc Check Valves

REASSEMBLY (Cont.)

4. Install stop shaft.

5. Install pipe plugs, using suitable thread compound to insure seal and to prevent galling.



Double Disc Check Valves

HOW TO CONTACT PRATT

HOW TO ORDER PARTS:

To order parts, contact our Parts Department:

Write: - Henry Pratt Company
401 South Highland Avenue
Aurora, IL 60506-5563

Attn: Parts Manager

Call - (630) 844-4000

Fax - (630) 844-4191

Please include valve serial number and description of part requested.

HOW TO OBTAIN SERVICE:

To obtain further information or secure field service, contact our Field Service Department:

Write: - Henry Pratt Company
401 South Highland Avenue
Aurora, IL 60506-5563

Attn: Field Service Manager

Call - (630) 844-4163

Fax - (630) 844-4160

Please include the following with your inquiry for service:

Henry Pratt Order Number:

Henry Pratt Item Number:

Valve Serial Number:

Type of Service Requested