

# AVK SUPA COUPLING, PN 16

**601**  
001

Universal Supa coupling, for water and sewage to max. 70° C, designed according to DIN/EN, Hydraulic test according to EN 1074-1 and 2 / EN 12266. Approved according to WRAS.

Universal coupling for cast iron, ductile iron, steel, uPVC and asbestos cement pipes. Centre sleeve and gland rings of ductile iron GJS-400-12 (GGG-40) with epoxy coating according to DIN 30677-2 - internally and externally. Sealing of EPDM rubber, with moulded ribs absorbing minor imperfections in the pipe. Bolts of PFTE coated stainless steel A2 and nuts of PFTE coated stainless steel A4. Washers of zinc plated hardened steel. Max.  $\pm 8^\circ$  deflection.



For further details see section "Technical Information".  
The designs, materials, and specifications shown are subject to change without notice due to the continuous development of our product programme.

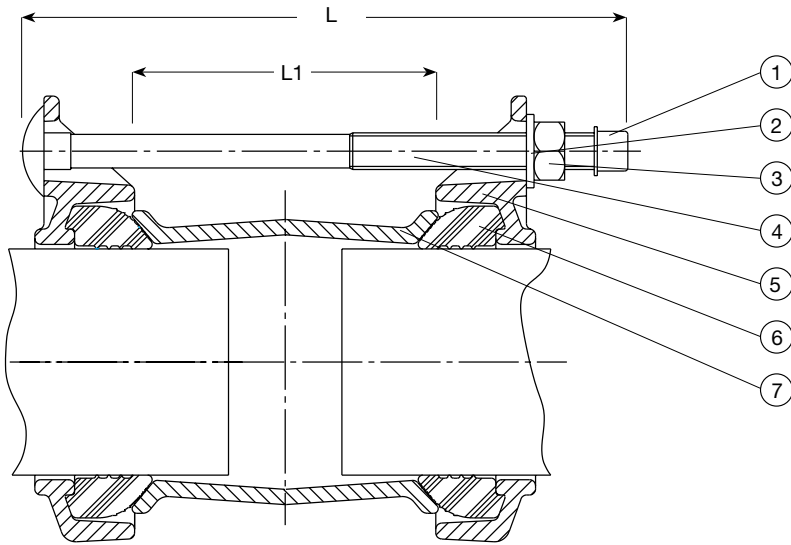

## Component list

1. End cap
2. Washer
3. Nut
4. Bolt
5. Gland ring
6. Rubber seal
7. Centre sleeve

## Reference nos. and dimensions

AVK ref. nos.	DN mm	L mm	L1 mm	PC2 mm	Theoretical weight kg
601-063-0006400	40	190	100	46-63	2,9
601-074-0006400	50	190	100	57-74	2,9
601-085-0006400	65	190	100	68-85	3,9
601-106-0006400	80	190	100	84-106	4,9
601-119-0006400	100	190	100	99-119	5,2
601-133-0006400	100	190	100	109-133	5,5
601-157-0006400	125	190	100	132-157	6,5
601-183-0006400	150	210	115	157-183	7,5
601-201-0006400	150	210	115	176-201	9,0
601-215-0006400	200	210	115	193-215	9,4
601-242-0006400	200	230	140	218-242	12
601-268-0006400	225	230	140	242-268	14
601-292-0006400	250	250	160	266-292	16
601-306-0006400	250	250	160	280-306	15
601-327-0006400	300	250	160	301-327	17
601-350-0006400	300	250	160	324-350	17
601-378-0006400	350	250	160	352-378	20
601-396-0006400	350	250	160	372-396	21
601-410-0006400	350	250	160	384-410	22
601-436-0006400	400	250	160	410-436	22
601-462-0006400	400	250	160	436-462	24